



SPARE PARTS LIST

TILE SAWS

MS 610, 967318201, 2018-08

A MS610
Blade Guard

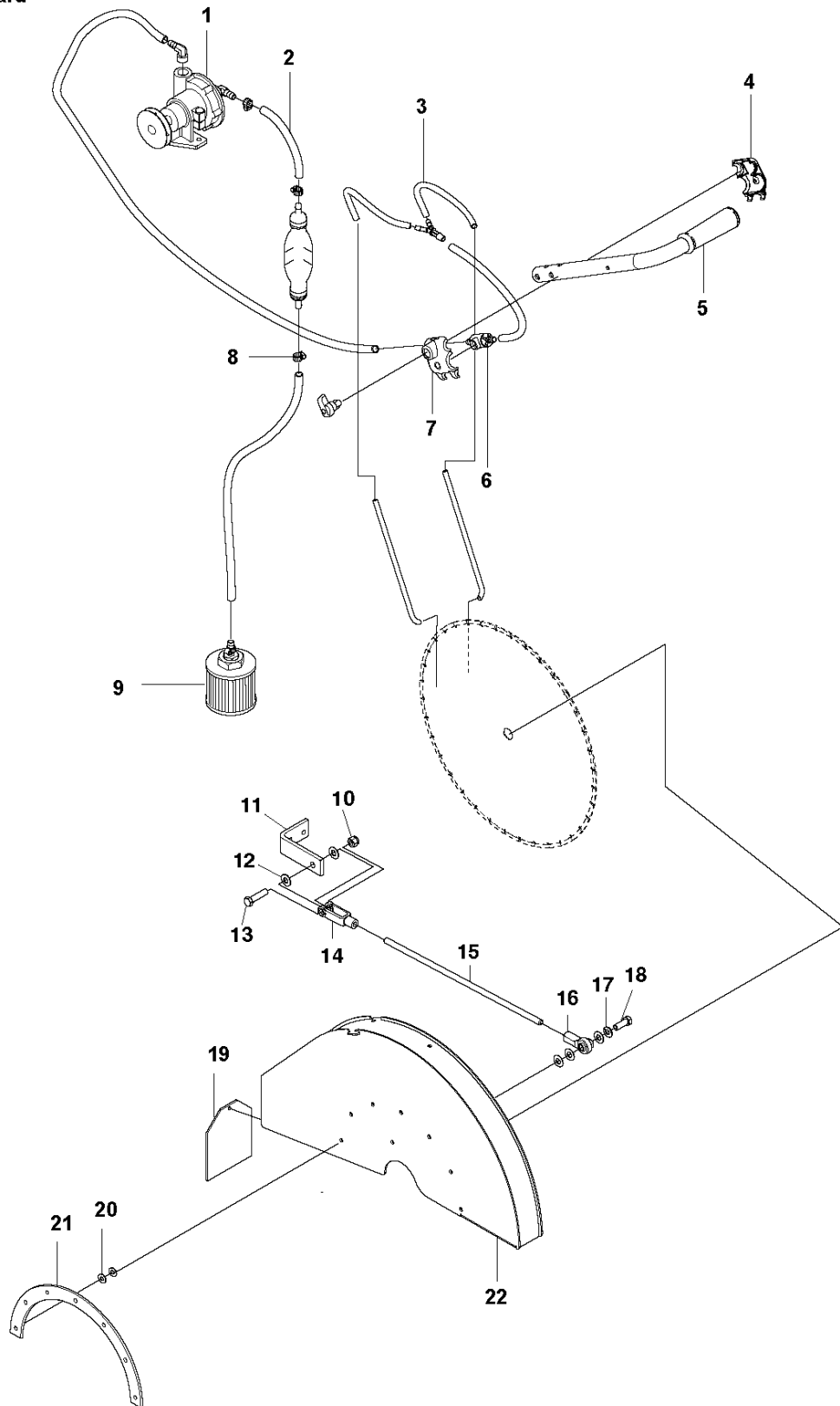

BLADE GUARD

MS 610, 967318201, 2018-08

Ref	Part No	Description	Remark	QTY KIT
1	542 17 73-17	PUMP		1
2	593 82 42-01	TUBING		1
3	541 20 07-07	TUBING	610mm	1
4	585 24 61-01	COVER		1
5	542 13 95-68	GRIP		1
6	586 69 51-01	VALVE ASSY		1
7	585 24 62-01	COVER		1
8	542 02 00-49	HOSE CLAMP		5
9	585 52 09-01	STRAINER		1
10	539 97 69-79	NUT		1
11	542 20 53-49	VALVE		1
12	539 99 01-22	WASHER		2
13	542 02 03-77	SCREW		1
14	542 06 04-60	YOKE		1
15	510 17 94-01	LINK		1
16	510 17 93-01	ROD END		1
17	539 99 01-18	WASHER		1
18	539 97 69-41	SCREW		1
19	542 16 93-65	SPLASH GUARD		1
20	539 99 00-55	WASHER 1/4 SAE		14
21	505 40 77-02	RING		1
22	589 73 74-01	BLADE GUARD		1

B MS610 Electric
Blade Guard

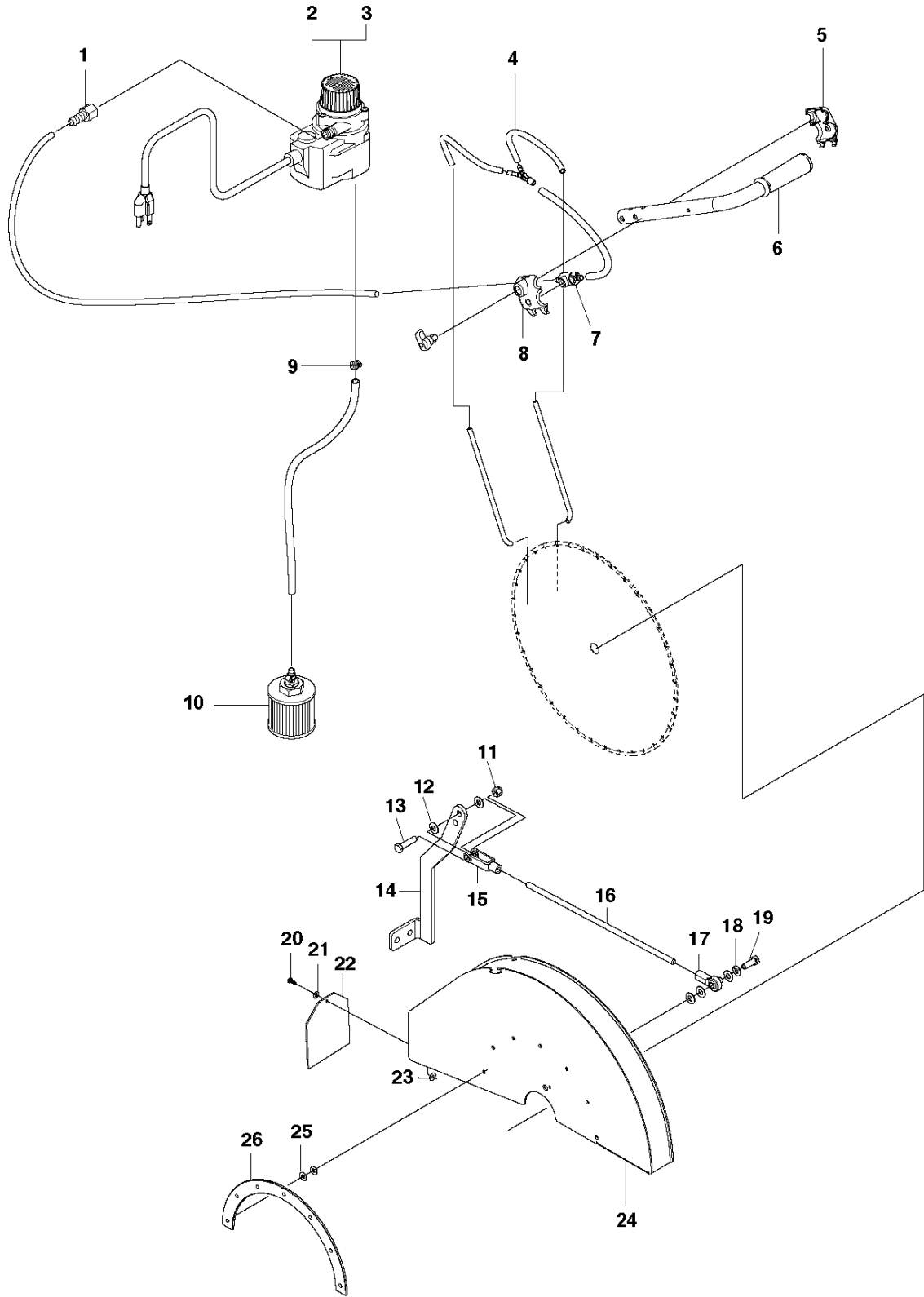

BLADE GUARD

MS 610, 967318201, 2018-08

Ref	Part No	Description	Remark	QTY KIT
1	542 03 06-54	INSERT		1
2	542 03 20-88	COLLECTOR	115V/50-60Hz	1
3	502 62 13-03	PUMP	230V/50-60Hz	1
4	541 20 07-07	TUBING	610mm	1
5	585 24 61-01	COVER		1
6	542 13 95-68	GRIP		1
7	586 69 51-01	VALVE ASSY		1
8	585 24 62-01	COVER		1
9	542 02 00-49	HOSE CLAMP		5
10	585 52 09-01	STRAINER		1
11	539 97 69-79	NUT		1
12	539 99 01-22	WASHER		2
13	542 02 03-77	SCREW		1
14	510 17 96-04	BRACKET		1
15	542 06 04-60	YOKE		1
16	510 17 94-01	LINK		1
17	510 17 93-01	ROD END		1
18	539 99 01-18	WASHER		1
19	539 97 69-41	SCREW		1
20	542 16 93-65	SPLASH GUARD		1
21	542 02 07-39	WASHER		1
22	542 16 93-65	SPLASH GUARD		1
23	505 63 04-01	NUT		1
24	589 73 74-01	BLADE GUARD	"20""	1
25	539 99 00-55	WASHER 1/4 SAE		14
26	505 40 77-02	RING		1

C MS610 Electric
Head Platform

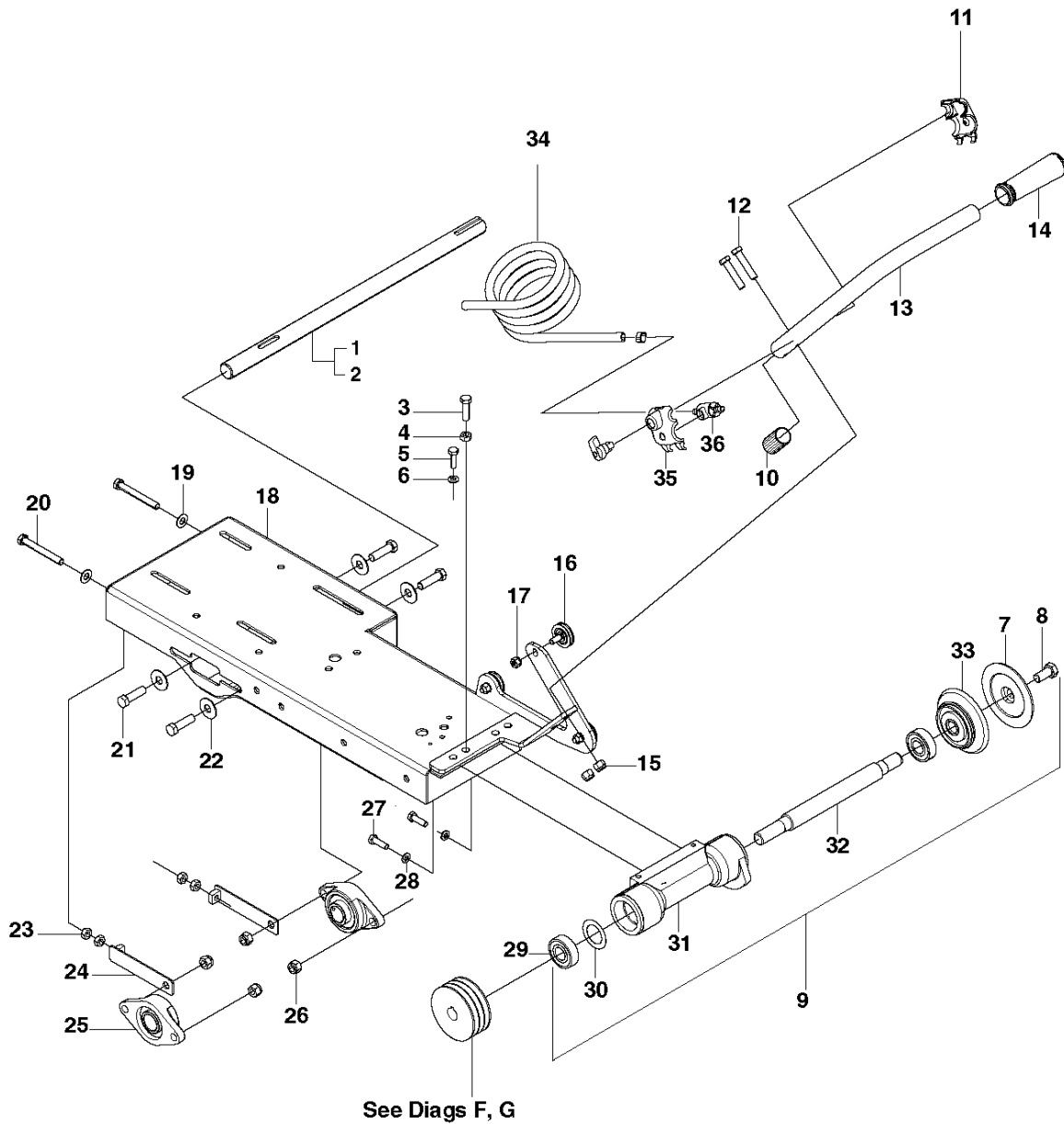

HEAD PLATFORM

MS 610, 967318201, 2018-08

Ref	Part No	Description	Remark	QTY	KIT
1	510 16 60-01	SHAFT	Electric	1	
2	510 16 60-02	SHAFT	Gas	1	
3	542 16 52-98	SCREW		2	
4	542 02 01-71	NUT		2	
5	504 73 65-07	PULLEY		2	
6	539 99 01-87	WASHER		4	
7	542130951	TBD		1	9
8	542 02 03-78	SCREW		1	9
9	542 20 54-37	BLADE SHAFT		1	
10	537 20 42-01	CONDUIT		1	
11	585 24 61-01	COVER		1	
12	539 99 07-30	SCREW		2	
13	510 26 03-01	HANDLE		1	
14	542 13 95-68	GRIP		1	
15	539 97 69-79	NUT		2	
16	581 24 02-01	WHEEL		1	
17	542 03 23-66	NUT		3	
18	510 16 19-07	BASE		1	
19	539 99 01-22	WASHER		2	
20	539 30 07-66	BOLT		2	
21	541 20 49-69	BOLT		4	
22	505 73 15-01	WASHER		4	
23	539 99 01-30	NUT		4	
24	574 24 42-01	BRACKET		2	
25	510 26 21-01	BEARING		2	
26	541 20 57-26	NUT		4	
27	504 73 65-07	PULLEY		2	
28	539 99 01-88	WASHER		2	
29	542 13 92-73	BALL BEARING		2	9
30	542 03 00-04	SPRING WASHER		1	9
31	542 20 53-42	HOUSING		1	9
32	542 19 50-17	BLADE SHAFT		1	9
33	542 17 79-73	COLLAR		1	9
34	523 12 03-04	HOSE		1	
35	585 24 62-01	COVER		1	
36	586 69 51-01	VALVE ASSY		1	

D MS610
Head platform

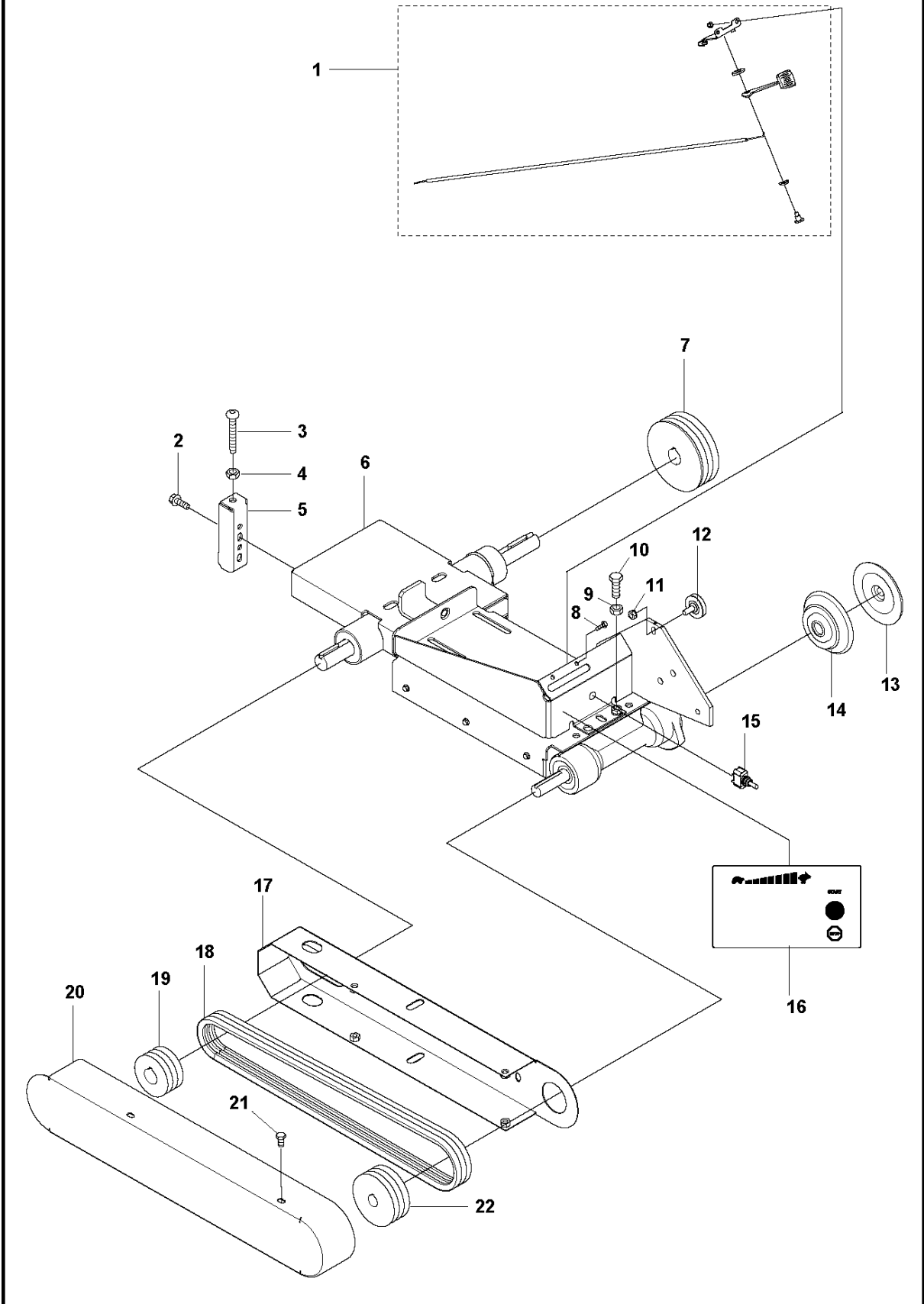

HEAD PLATFORM

MS 610, 967318201, 2018-08

Ref	Part No	Description	Remark	QTY KIT
1	587 69 69-01	CABLE		1
2	585 97 54-01	SCREW EHHFM		5
3	542 20 63-24	SCREW		1
4	731 43 18-01	HEXAGON THIN NUT		1
5	591 20 08-01	BRACKET		1
6	590 37 71-01	ARM		1
7	542 19 54-06	PULLEY		1
8	585 98 05-01	SCREW EHHFM		2
9	542 02 01-71	NUT		4
10	542 16 81-33	SCREW		1
11	542 03 23-66	NUT		3
12	523 07 52-01	BEARING		3
13	542 03 09-51	FLANGE		1
14	542 17 79-73	COLLAR		1
15	542 19 96-48	SWITCH		1
16	592 78 74-01	DECAL		1
17	542 19 52-32	GUIDE BAR		1
18	542 04 53-98	V-BELT		3
19	542 13 96-83	PULLEY		1
20	542 20 53-46	BELT GUARD		1
21	592 85 87-01	BOLT		4
22	542 19 52-35	PULLEY		1

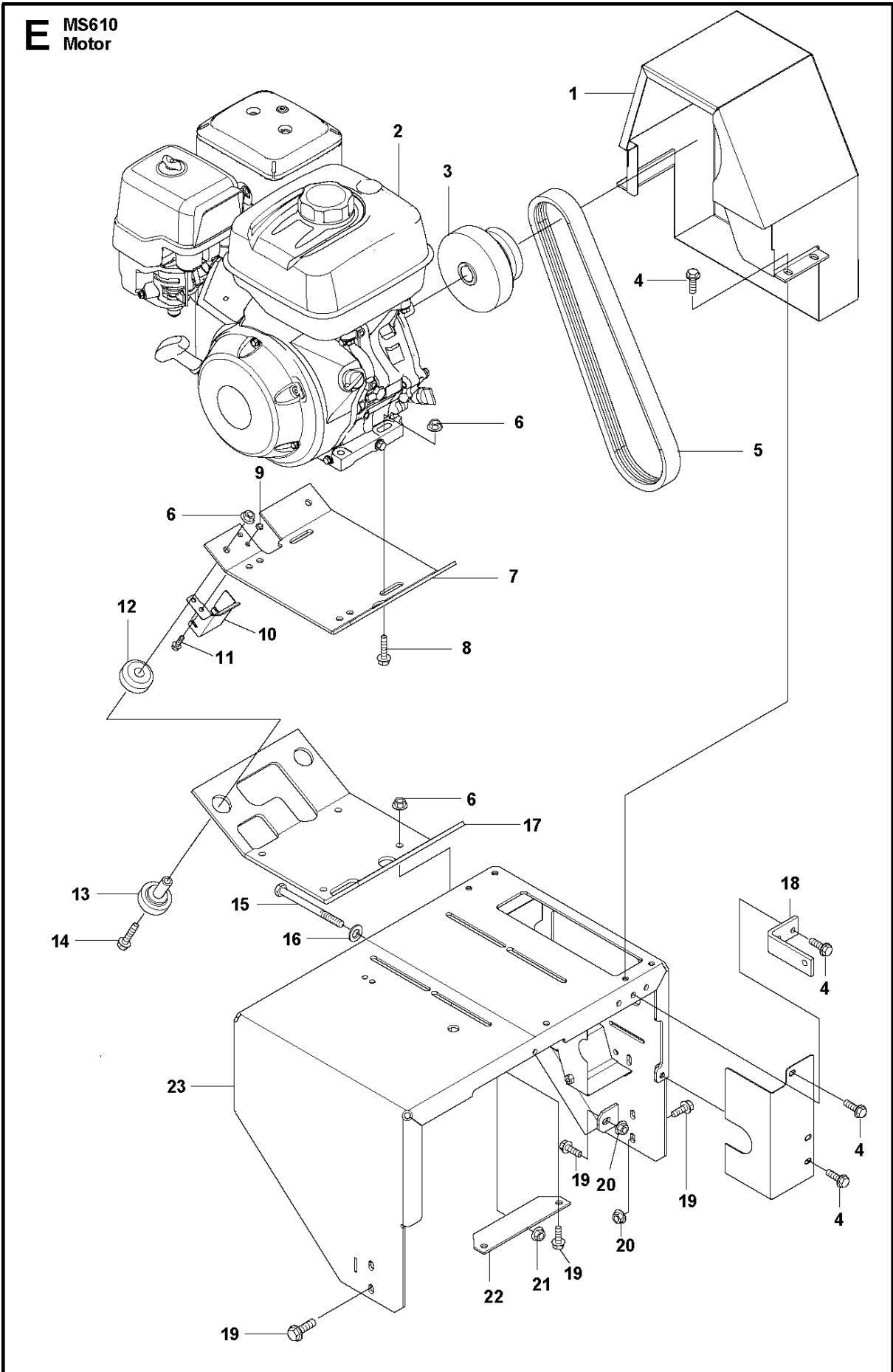

MOTOR

MS 610, 967318201, 2018-08

Ref	Part No	Description	Remark	QTY KIT
1	590 74 06-01	BELT GUARD ASSY		1
2	589 46 79-01	ENGINE		1
3	542 19 52-55	CLUTCH		1
4	585 97 54-01	SCREW EHHFM		9
5	542 19 04-16	V-BELT		1
6	576 64 57-05	NUT FLANGE		12
7	590 37 69-01	BRACKET		1
8	581 54 82-01	SCREW EHHFM		4
9	732 25 16-01	HEXAGON LOCKING NUT		2
10	510 18 32-01	BRACKET		1
11	585 98 06-01	SCREW EHHFM		2
12	542 16 11-97	ISOLATOR		2
13	542 16 11-97	ISOLATOR		2
14	581 24 33-01	SCREW EHHFM		4
15	542 19 50-39	SCREW		1
16	539 99 02-50	WASHER		1
17	590 37 68-01	BRACKET		1
18	542 20 53-49	VALVE		1
19	585 97 31-01	SCREW EHHFM		6
20	731 71 20-51	HEXAGON NUT FLANGE		6
21	523 32 77-01	NUT		1
22	542 20 53-47	BRACKET		1
23	589 33 56-01	BRACKET		1

F MS610 Electric Motor, Pulleys & Belts

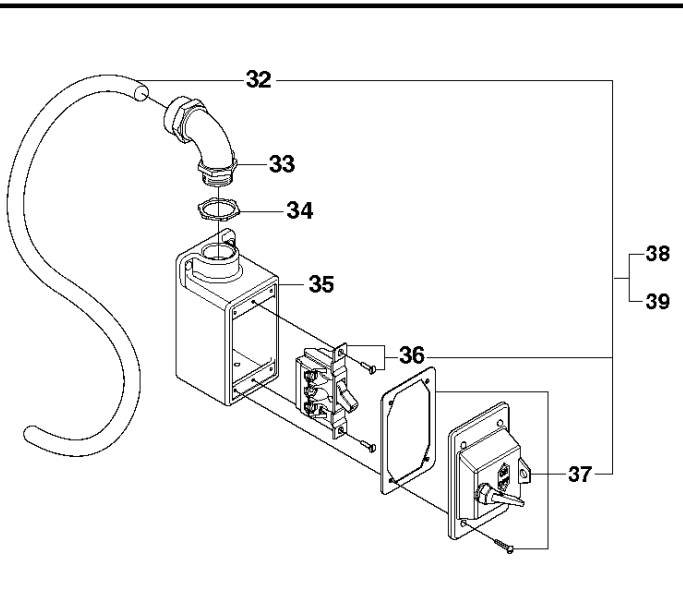
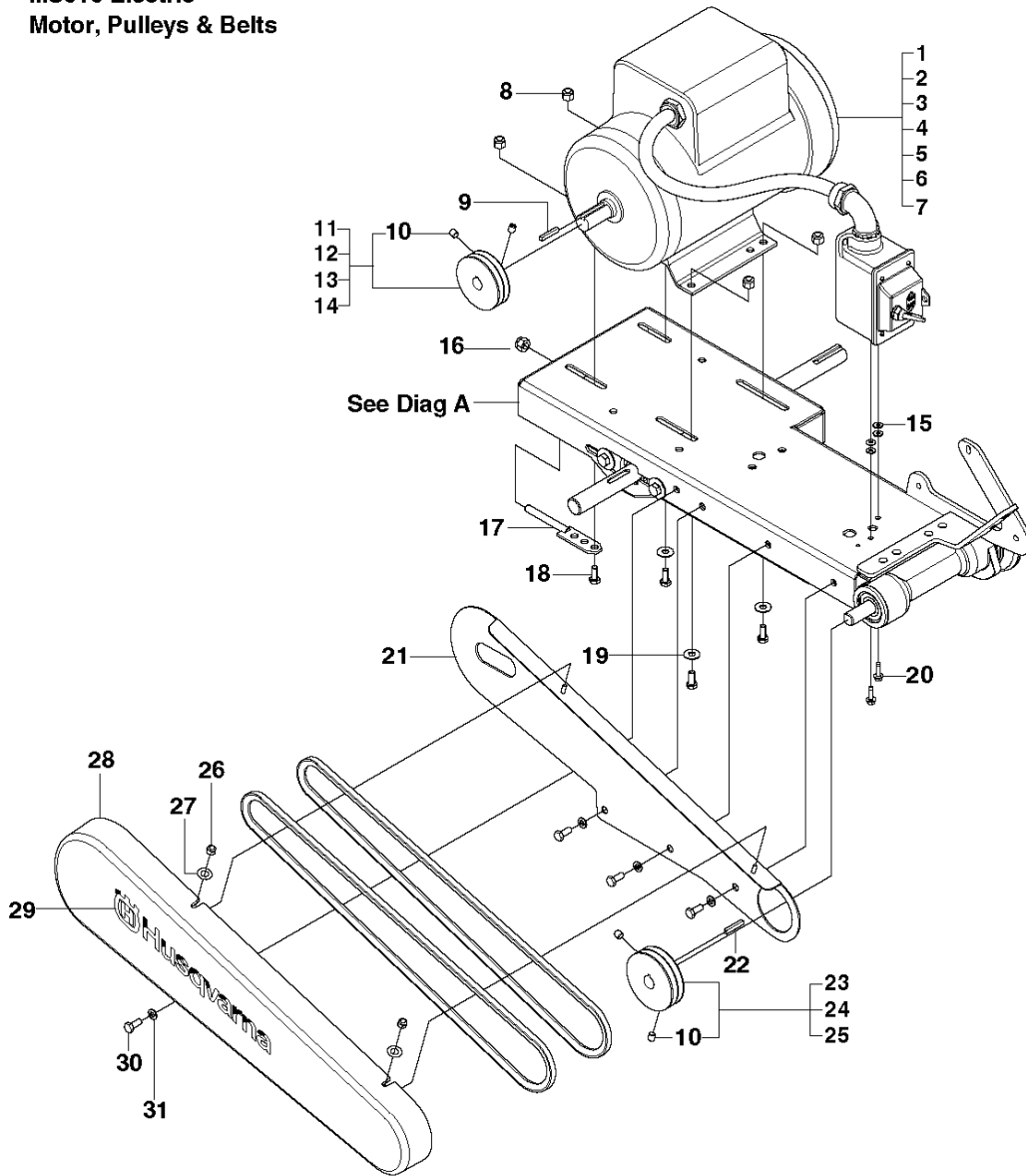

WOOD MOTOR PERFORMANCE DEPENDS ON PROPER VOLTAGE. OVERVOLTAGE CAN BE DANGEROUS TO OPERATOR. ALWAYS INSURE VOLTAGE TO MOTOR UNDER LOAD. USE EXTENSION CORDS NO SMALLER THAN INDICATED BELOW.

MODEL	HP	AMP	HP	AMP	HP	AMP
MS 610	1.5	10	2.0	13	2.5	17
MS 610	1.5	10	2.0	13	2.5	17
MS 610	1.5	10	2.0	13	2.5	17

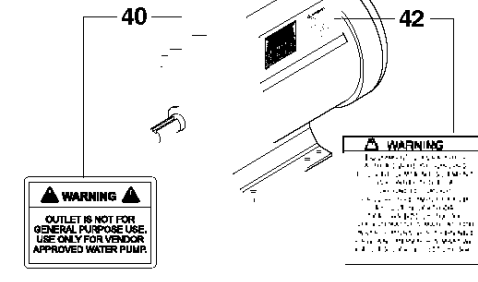

WARNING
 OUTLET IS NOT FOR GENERAL PURPOSE USE. USE ONLY FOR VENDOR APPROVED WATER PUMP.

WARNING
 Equipment is not to be used for any purpose other than that intended by the manufacturer. Do not use for any purpose other than that intended by the manufacturer. Do not use for any purpose other than that intended by the manufacturer. Do not use for any purpose other than that intended by the manufacturer.

MOTOR, PULLEYS & BELTS

MS 610, 967318201, 2018-08

Ref	Part No	Description	Remark	QTY	KIT
1	542 16 96-56	MOTOR	3HP 60Hz-1Ph	1	
2	542 16 96-22	MOTOR	5HP 60Hz-1Ph	1	
3	542 00 08-06	MOTOR	3HP 60Hz-3Ph	1	
4	542 00 09-23	MOTOR	5HP 60Hz-3Ph	1	
5	542 00 09-25	MOTOR	5HP 60Hz-3Ph 575V	1	
6	542 16 20-42	MOTOR	5HP 50Hz-1Ph	1	
7	542 17 03-10	MOTOR	5HP 50Hz-3Ph	1	
8	539 97 69-79	NUT		4	
9	542 02 00-62	KEYBOARD		1	
10	542 02 05-50	SCREW		4	11, 12, 13, 14, 22, 23, 24
11	542 03 09-06	PULLEY	"20"" -60Hz"	1	11
12	542 06 01-39	PULLEY	"20"" -50Hz"	1	12
13	542 03 09-31	PULLEY 2G3V3.0 - .875 W/SS	"14"" -60Hz"	1	13
14	542 03 09-02	PULLEY	"14"" -50Hz 2-Piece Pulley"	1	14
15	541 20 57-64	WASHER		4	
16	539 97 69-79	NUT		1	
17	542 17 76-96	BOLT		1	
18	539 99 05-63	SCREW		3	
19	539 99 05-17	WASHER		4	
20	539 99 05-80	SCREW		2	
21	510 15 43-01	MANIFOLD		1	
22	542 02 00-62	KEYBOARD		2	
23	542 03 09-21	PULLEY 2G3V3.35 - .75 W/SS	"14-20"" -60Hz"	1	23
24	542 06 01-06	PULLEY	"20"" -50Hz"	1	24
25	542 06 01-05	PULLEY	"14"" -50Hz 2-Piece Pulley"	1	25
26	539 97 69-78	NUT		2	
27	541 20 57-64	WASHER		2	
28	542 20 53-80	BELT GUARD		1	
29	542 19 07-33	DECAL		1	
30	539 97 69-34	SCREW		4	
31	539 99 01-87	WASHER		4	
32	542 18 08-09	CABLE		1	38, 39
33	542 18 08-15	CONNECTOR		1	38, 39
34	542 17 69-53	LOCK NUT		1	38, 39
35	542 18 08-14	SWITCH		1	38, 39
36	542 16 15-81	SWITCH	1-Phase Only	1	38
37	542 03 25-41	COVER		1	38, 39
38	542 18 08-10	SWITCH	Compl (1-Phase)	1	38
39	542 03 00-71	SWITCH, ASSY DUST PROOF W/WIRE	Compl (3-Phase)	1	39
40	542 18 92-47	DECAL		1	
41	542 04 63-27	DECAL		1	
42	542 04 63-26	DECAL		1	

G MS610 Electric Motor, Pulleys & Belts

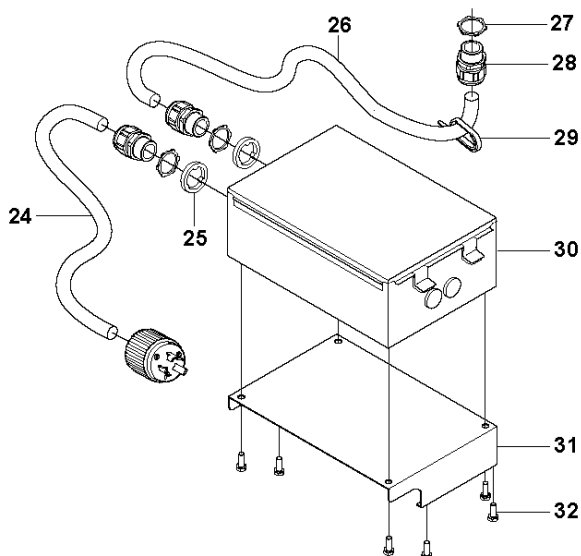
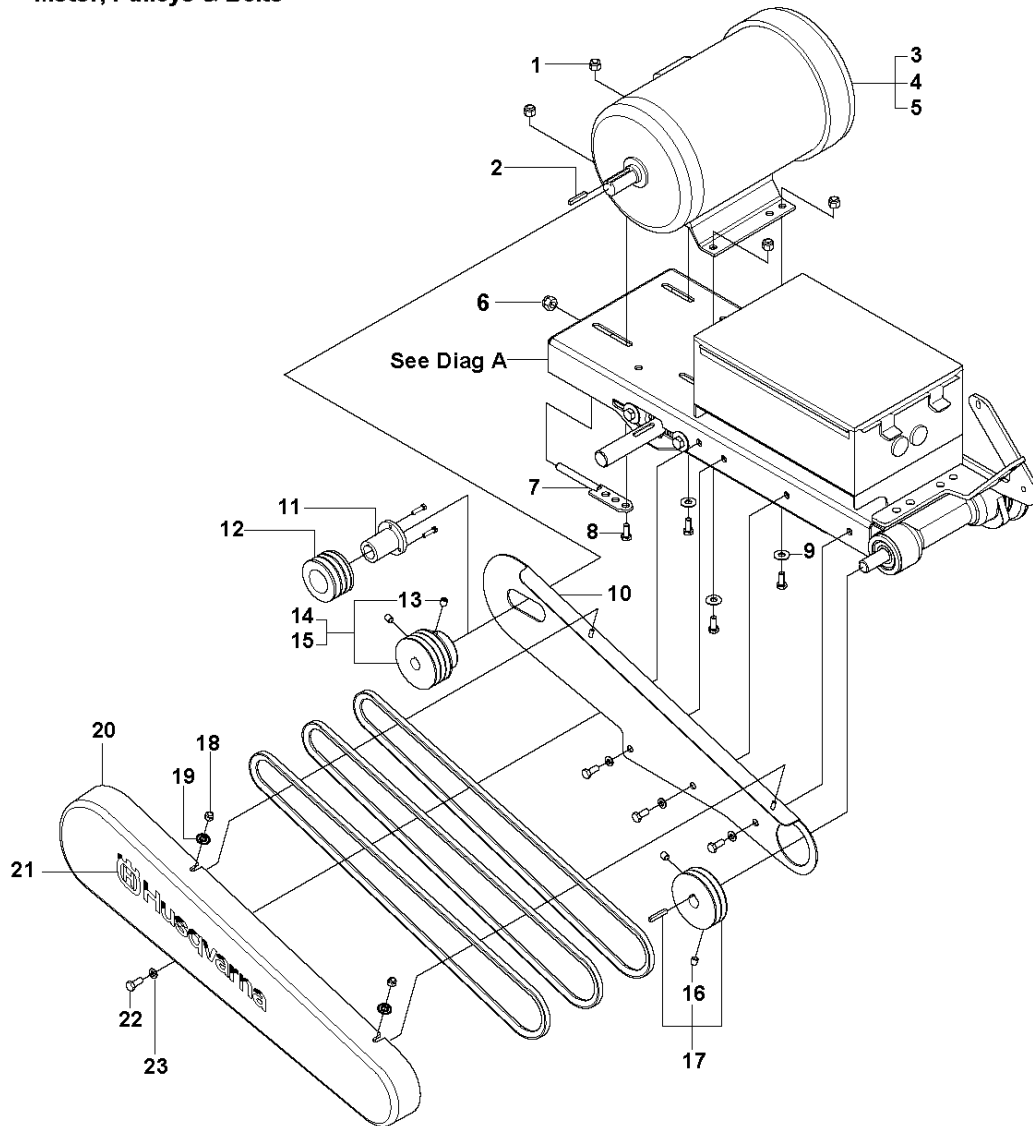

WARNING
 OUTLET IS NOT FOR
 GENERAL PURPOSE USE.
 USE ONLY FOR VENDOR
 APPROVED WATER PUMP.

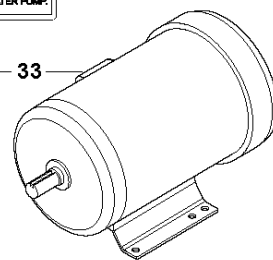

Ref	Part No	Description	Remark	QTY	KIT
1	539 97 69-79	NUT		4	
2	542 02 00-62	KEYBOARD		1	
3	542 00 12-65	MOTOR	230/460V 60Hz	1	
4	542 00 12-57	MOTOR	575V 60Hz	1	
5	542 00 12-70	MOTOR	220/380V 50Hz	1	
6	539 97 69-79	NUT		1	
7	542 17 76-96	BOLT		1	
8	539 99 05-63	SCREW		3	
9	539 99 05-17	WASHER		4	
10	510 15 43-01	MANIFOLD		1	
11	542 16 20-53	HUB	"20"" -50Hz"	1	
12	542 13 92-59	PULLEY	"20"" -50Hz"	1	
13	542 02 05-50	SCREW		2	14, 15
14	542 03 09-16	PULLEY	"14""	1	14
15	542 03 09-19	PULLEY	"20"" -60Hz"	1	15
16	542 02 05-41	KEY		2	17
17	542 19 52-36	PULLEY		1	17
18	539 97 69-78	NUT		2	
19	541 20 57-64	WASHER		2	
20	542 20 53-80	BELT GUARD		1	
21	542 19 07-33	DECAL		1	
22	539 97 69-34	SCREW		4	
23	539 99 01-87	WASHER		4	
24	542 18 20-18	CORD	3.5'	1	
25	542 17 69-33	SEALING RING		2	
26	542 18 20-18	CORD	3.17'	1	
27	542 17 69-53	LOCK NUT		3	
28	542 18 20-24	CONNECTOR		3	
29	542 19 71-01	CABLE		1	
30	502 47 26-01	BOX		1	
31	504 10 40-02	BRACKET		1	
32	539 99 05-80	SCREW		8	
33	542 18 92-47	DECAL		1	

H MS610
Cart

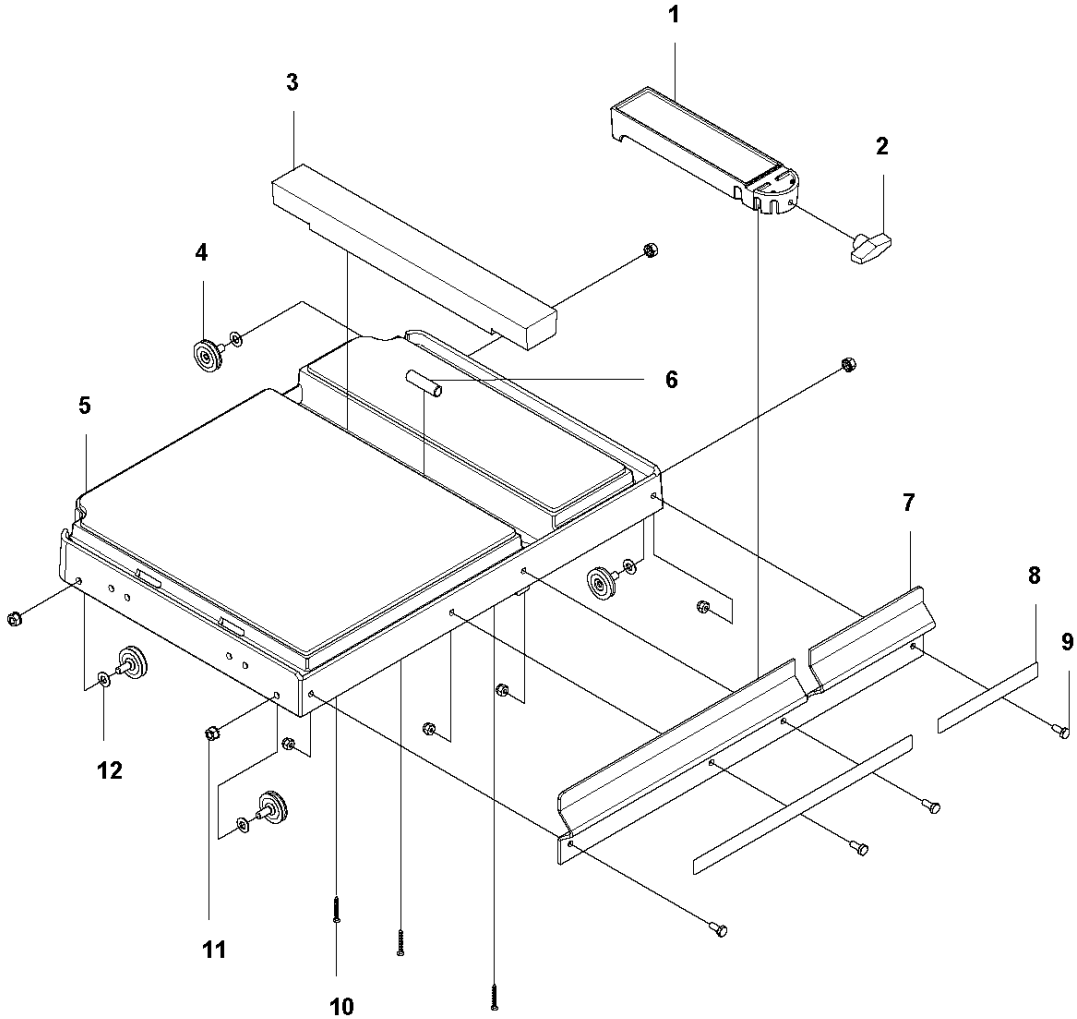

Ref	Part No	Description	Remark	QTY KIT
1	542 03 03-55	GUIDE		1
2	542 18 09-87	KNOB		1
3	542 17 78-94	INSERT		1
4	523 07 52-01	BEARING		4
5	510 41 75-05	STOP		1
6	542 17 00-38	TUBE		1
7	542 18 60-57	CART		1
8	542 17 79-76	SPRING		1
9	542 02 03-01	SCREW		4
10	542 17 79-04	SCREW		3
11	539 97 69-78	NUT		4
12	539 99 01-88	WASHER		4

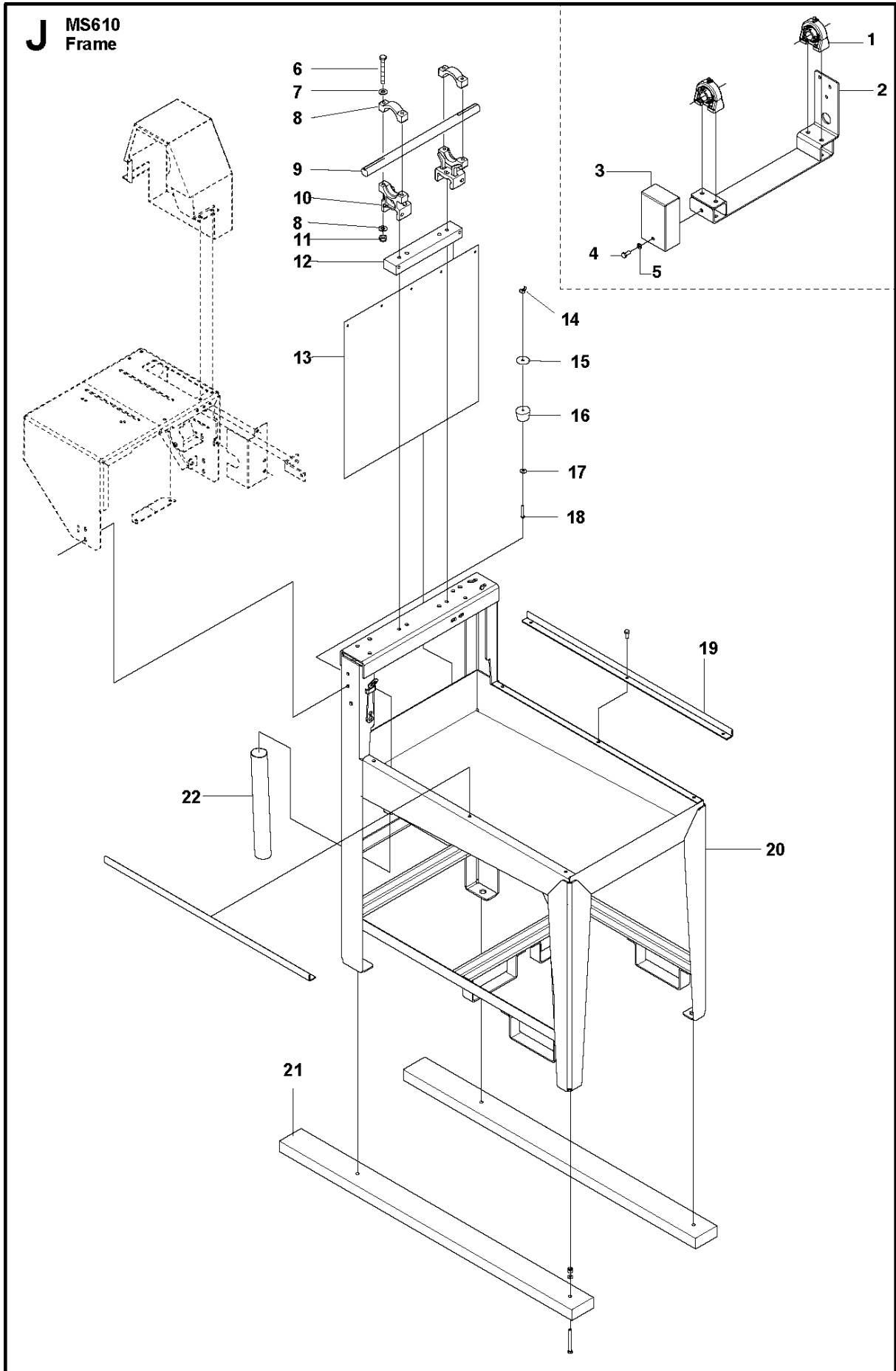

FRAME

MS 610, 967318201, 2018-08

Ref	Part No	Description	Remark	QTY KIT
1	542 04 52-41	BEARING		1
2	510 17 90-11	PIVOT		1
3	510 17 91-08	GUARD		1
4	539 97 69-34	SCREW		1
5	539 99 01-87	WASHER		1
6	505 72 19-01	BOLT		4
7	539 99 01-88	WASHER		18
8	542 18 62-56	SUPPORTING BEARING		2
9	542 19 52-37	SHAFT		1
10	542 18 62-54	SUPPORTING BEARING		2
11	539 99 07-17	NUT		8
12	589 33 51-01	SPACER PLATE		1
13	521 95 09-02	GUIDE BAR		1
14	542 02 02-34	NUT		1
15	542 03 03-93	SCREW		1
16	542030394	TBD		1
17	541 20 57-64	WASHER		1
18	542 02 04-19	BOLT		1
19	510 14 08-02	RAIL		2
20	589 33 57-01	FRAME ASSY		1
21	505 43 01-01	SUPPORT		2
22	542 03 23-42	HOSE		1